

Gewinde M3

75° min.

DETAIL A
MAßSTAB 1 : 1

A

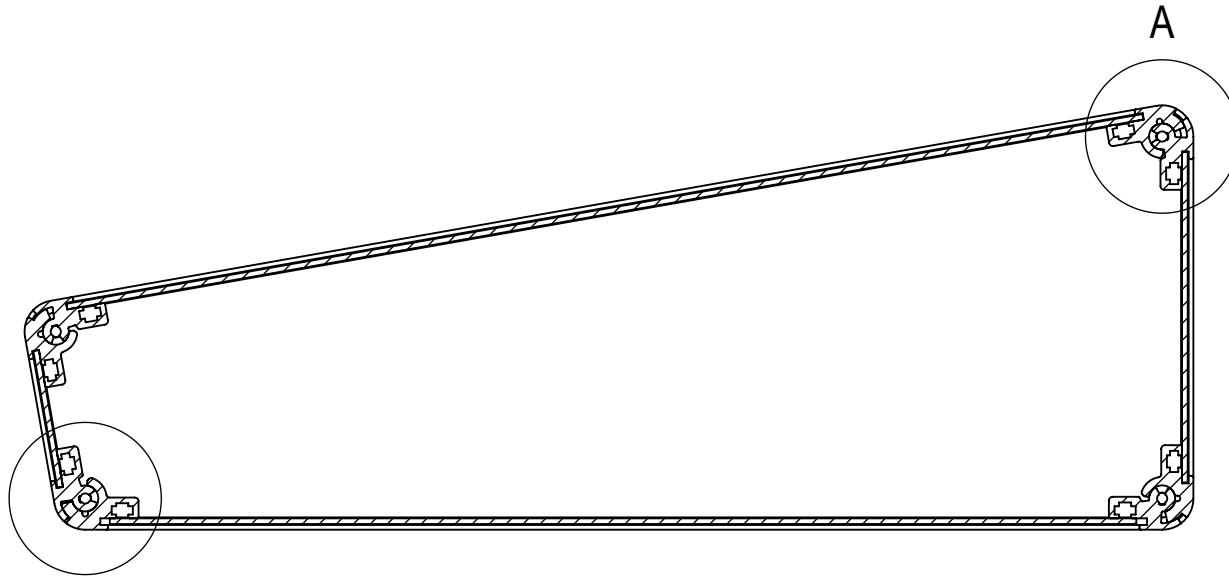

SCHNITT C-C

B

105° max.

DETAIL B
MAßSTAB 1 : 1

